

DIESEL LOCOMOTIVE FINAL DRIVE

REVERSE & REDUCTION
GEARBOXES

RF 11 & RF 25

Jackshaft or Frame-
Mounted Units

100 – 250 H.P.

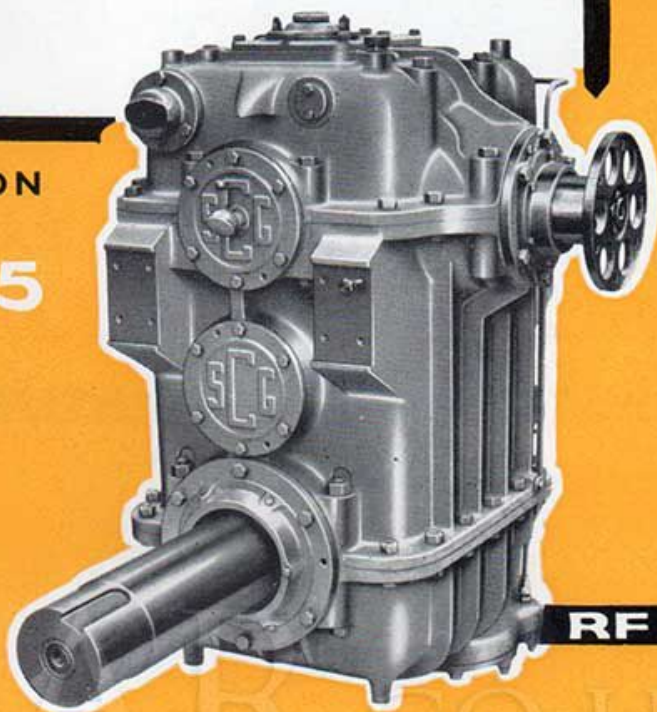

RF 11



RF 25

THESE extremely robust units have been designed to withstand the heavy buffing and drawbar shocks associated with shunting locomotives at work, and yet offer extreme lightness and simplicity of control.

Pneumatic operation of the reversing mechanism ensures immediate response to control movements which require no effort on the driver's part. Positive engagement is maintained by continuous air pressure within the selector unit. Manual operation can be provided if required.

The RF11 unit, which has a maximum capacity of 300 h.p., can be adapted to either jackshaft or frame mounting, to suit particular design requirements, whilst in the wide range of overall ratios available, from 5:1 to 12.44:1 (maximum), will be found a suitable ratio for most diesel locomotive operating conditions.

Our RF25 unit, which is somewhat smaller, with a maximum capacity of 150 h.p. can only be adapted to jackshaft mounting. The higher maximum ratio of 10.37:1 given by this unit makes it very versatile where the smaller capacity is desired.

Over 400 of these units are giving hard and continuous service in all parts of the world. With their sturdy construction, lightness and certainty of operation, requiring only the minimum of maintenance, these units can be depended upon for efficient service under the most trying conditions.



SELF-CHANGING GEARS LTD

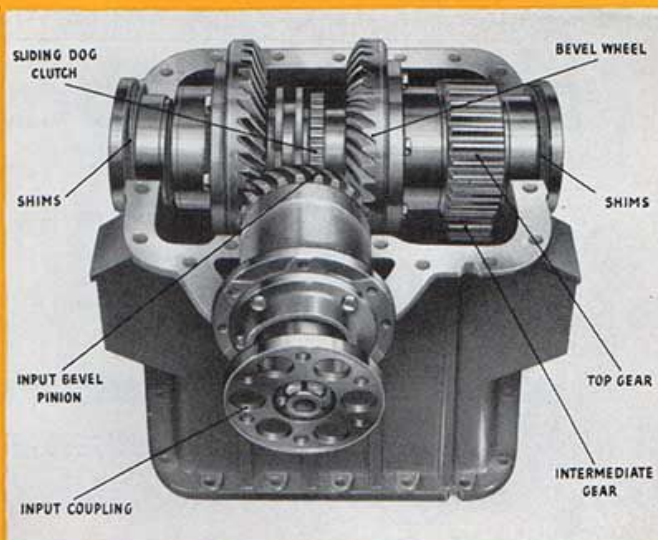
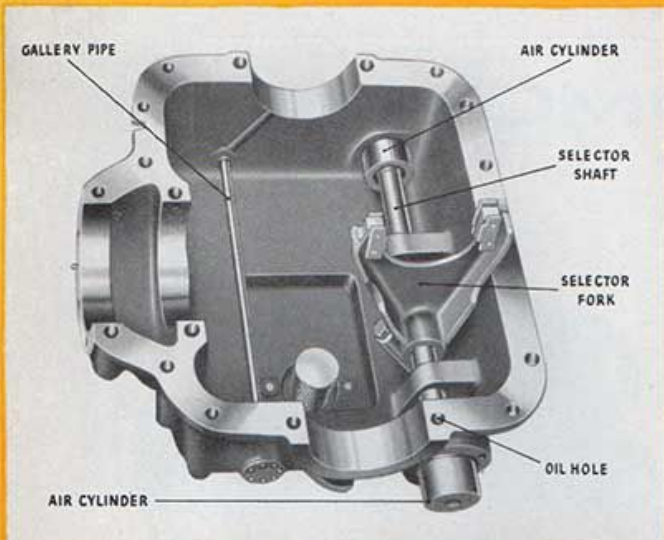

CONSTRUCTIONAL FEATURES . . .

SIMPLE AIR OPERATION

The sliding dog clutch is moved into engagement by a selector fork mounted upon the selector shaft shown in the illustration. A movement of the driver's control lever allows air to enter a cylinder at one end of the selector shaft to select forward or reverse as required.

The gallery pipe from which oil sprays upon the bevel wheels is also shown.

HARDENED AND GROUND GEARS

The reduction gears keyed to the top shaft and jackshafts are of the straight spur type, case-hardened and ground for maximum efficiency and silence. The intermediate gear is a press fit on the intermediate shaft. The jackshaft gear is a 60-ton press fit on the jackshaft.

SPIRAL BEVEL REVERSING GEAR

Lapped spiral bevel gears consisting of an input bevel pinion, meshing with two bevel wheels mounted on the top shaft, comprise the reversing mechanism of the gearbox. A sliding dog clutch connects one or the other of the bevel wheels to the top shaft. The drive is then taken through the top gear to the reduction gearing below.

BEARINGS

Heavy duty taper roller and roller bearings throughout support the shafts, and although the total weight of the RF11 unit is some 35 cwts., the entire gearing can be rotated by the pressure of a finger on the input coupling.

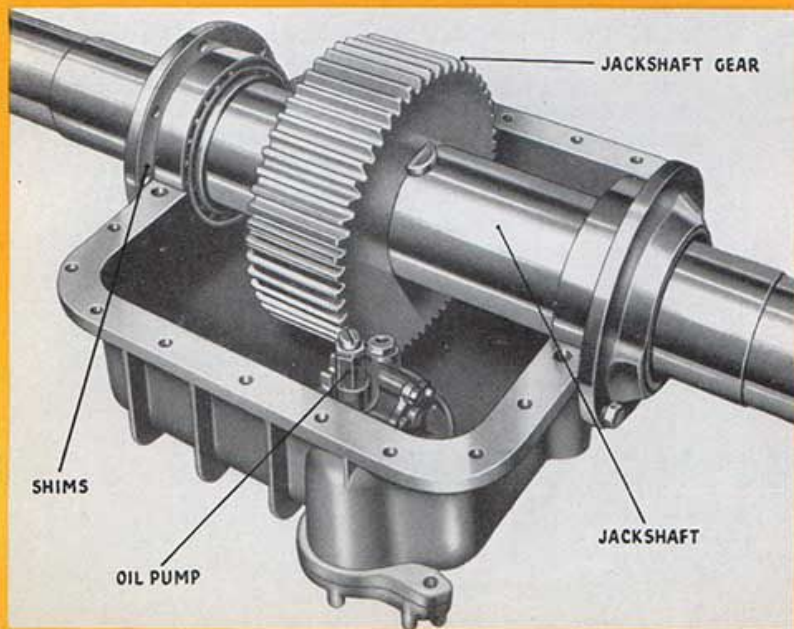

LUBRICATION

Lubrication of the jackshaft gear and intermediate pinion is effected by the jackshaft gear dipping in oil. The jackshaft bearings run in oil.

A submerged bi-directional oil pump supplies oil under pressure to the top and intermediate shaft bearings. Jets of oil from a gallery pipe supplies lubrication for all other gears and bearings.



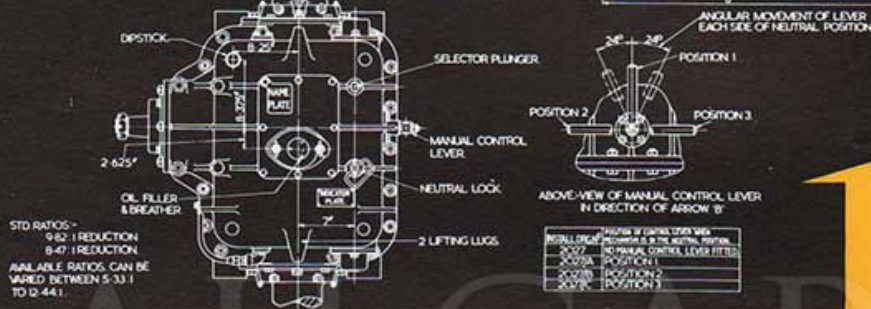
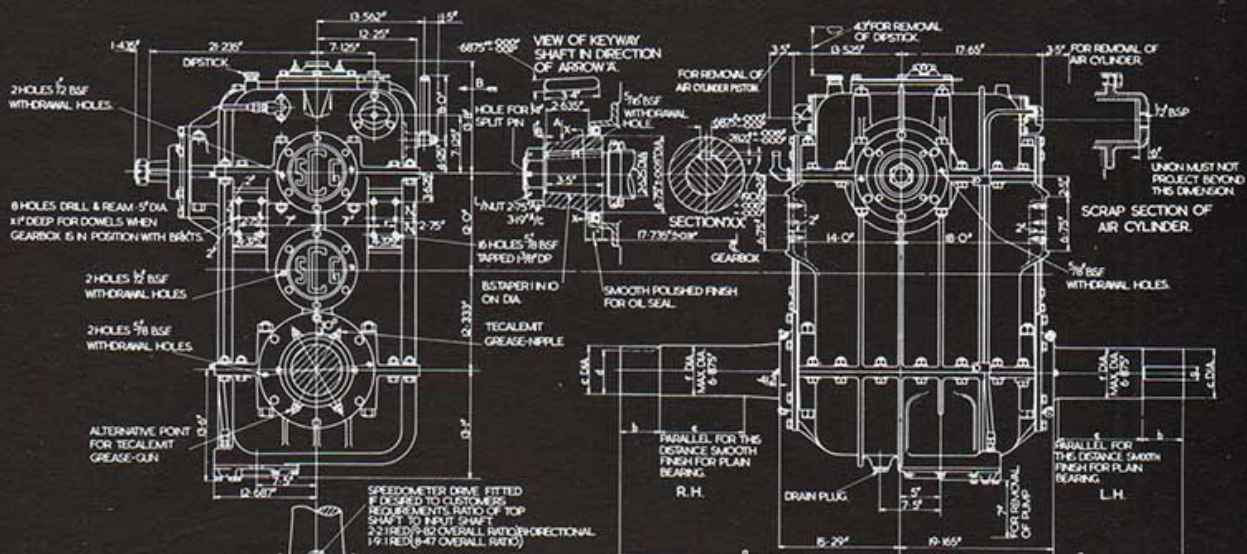

RF 11

DIESEL LOCOMOTIVE FINAL DRIVE INSTALLATION DRAWINGS

RF 25

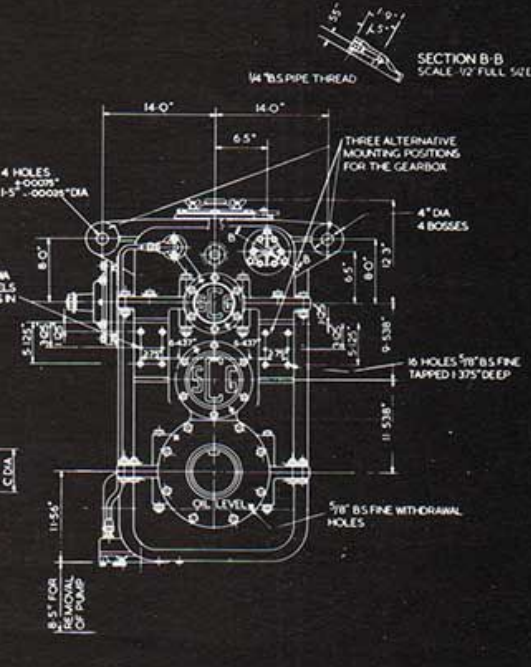
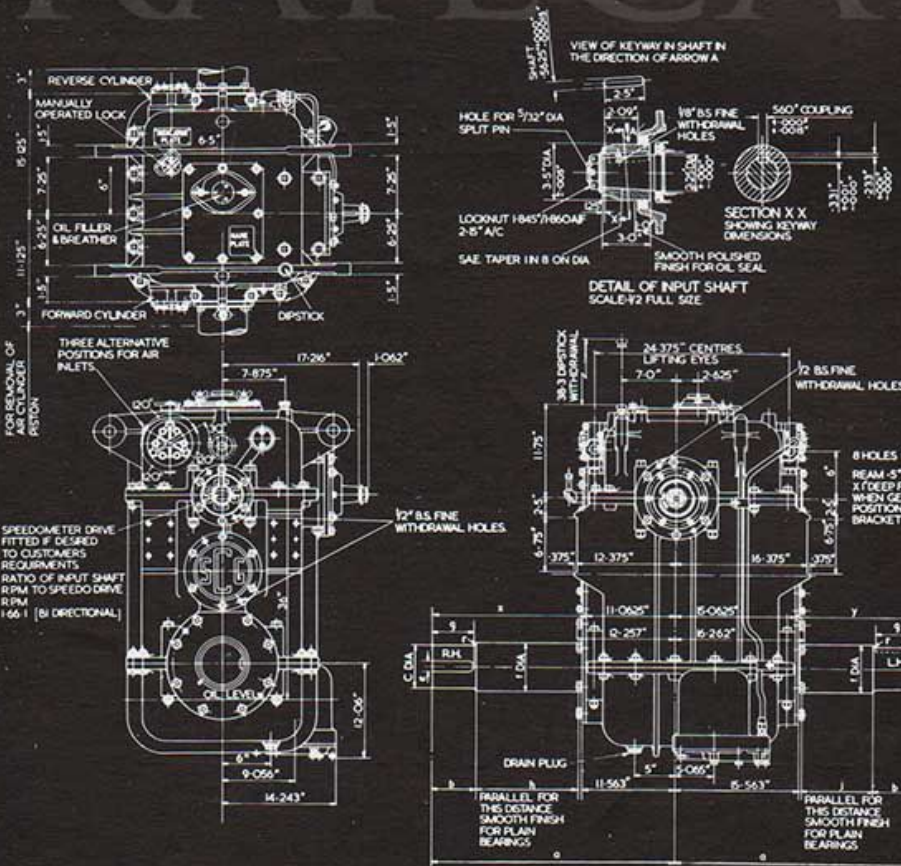

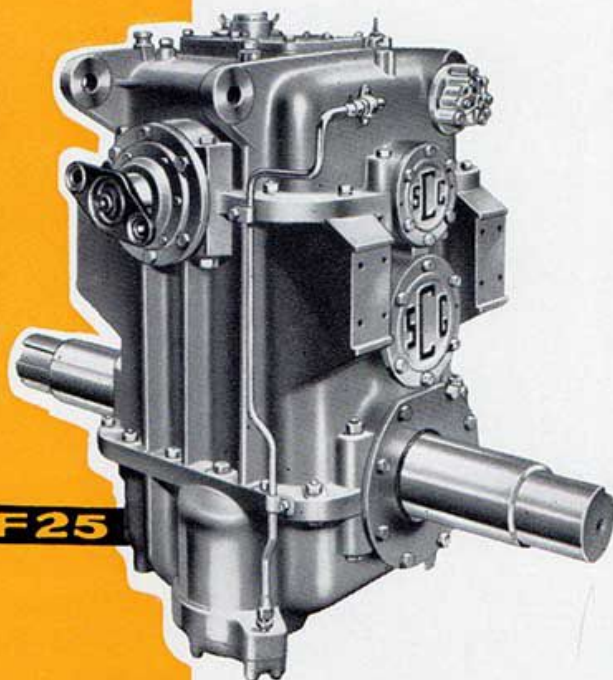
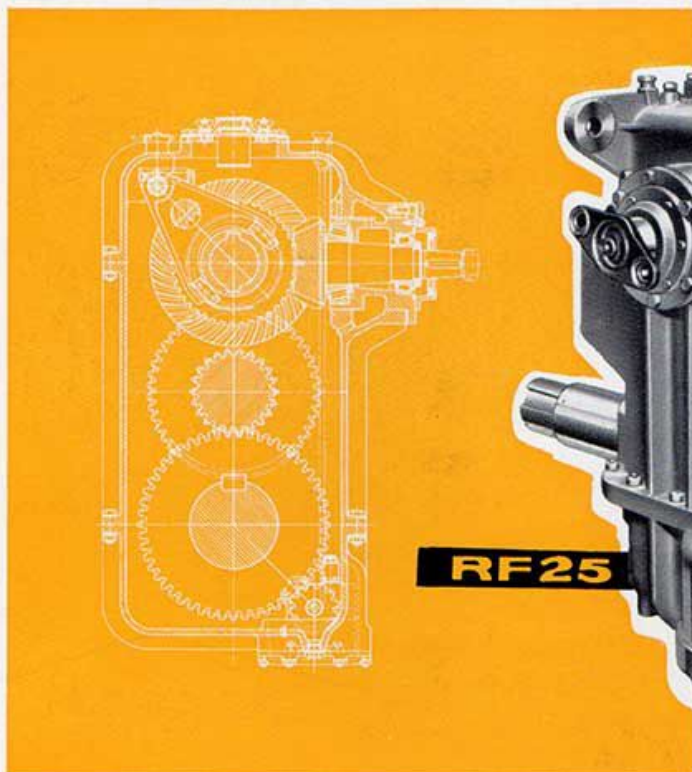

OPERATING PRINCIPLES OF THE RF11 & RF25

The drive from a change speed gearbox is taken through the input bevel pinion assembly which is clearly shown on the sectional drawing above.

An air-operated sliding dog clutch engages this drive with one or the other of the bevel wheels to rotate the top shaft.

A spur type gear transmits this torque through a mating gear on the intermediate shaft to the jackshaft on which the unit (in one of its forms) is mounted.

A torque arm fitted to the casing, with the jackshaft mounted in bearings in the sub-frame, gives a three-point suspension for the unit.

Facings can be provided on the RF11 casing, however, for sub-frame mounting of the entire unit if this is desired.

The gearbox incorporates a neutral lock for the selector shaft which is applied to keep the unit in neutral when the locomotive is being towed.

These rugged and efficient units with their effortless system of control, carefully balanced design and precision construction meet all the operating requirements of diesel locomotives in the 100—300 h.p. class.

DATA

	RF11	RF25
Max Torque	6,000 lbs. ft.	3,000 lbs. ft.
Capacity	(830 Kg.m.)	(415 Kg.m.)
* Standard Ratios	9.82:1, 8.47:1	8.95:1
Air Pressure	50—80 lbs. p.s.i. (3.52—5.62 Kg.p.s.cm.)	50—80 lbs. p.s.i.
Weight (with oil)	34½ cwt. approx (1,760 Kg.)	28 cwt. approx. (1,425 Kg.)
Shipping	1 case	1 case
Specification	3' 3" (1.00 m)	5' 3" (1.6 m)
	6' 0" (1.83 m)	4' 2" (1.27 m)
	4' 6" (1.37 m)	3' 0" (0.90 m)
	40 cwt. gross (2,040 Kg.)	32 cwt. gross (1,630 Kg.)

* Other ratios are possible. Please consult us for details.



SELF-CHANGING GEARS LTD

LYTHALLS LANE . COVENTRY . ENGLAND

Telephone : Coventry 89081

Telegrams : Self-Change Coventry

Produced by Self-Changing Gears Ltd. 1500/58

FGR Ltd. Printed in England